







Extrait de catalogue SNR.....

Les roulements des autres BV d'après SNR.....

 336					
<b>10Q 30207 A</b>	7703090179	37	72	18,25	
<b>10R 30205 A</b>	7703090167	25	52	16,25	
<b>30203 A</b>	7703090182	17	40	13,25	
<b>30207 A</b>	7703090187	35	72	18,25	
<b>FC 10558 V</b>	7703090181	25	67/75	40,5	
<b>N.10787</b>	7703090201	32	72	19	

**10Q 30207 A**

7703090179      37      72      18,25



**10R 30205 A**

7703090167      25      52      16,25



**30203 A**

7703090182      17      40      13,25



**30207 A**

7703090187      35      72      18,25



**32304 A**

7703090180      20      52      22,25



**FC 10558 V**

7703090181      25      67/75      40,5



**N.10787**

7703090201      32      72      19



BV 352 4 vitesses.....R12; R15; R17; R18; R20.....

Dans les boites 352, je pense que le roulement du pignon d'attaque de couple conique est la référence FR10273 ou FR10319 ou BR10552 à rainure décentrée contrairement à ce qui est indiqué ci-dessus.



# Doc SNR 2007.

365

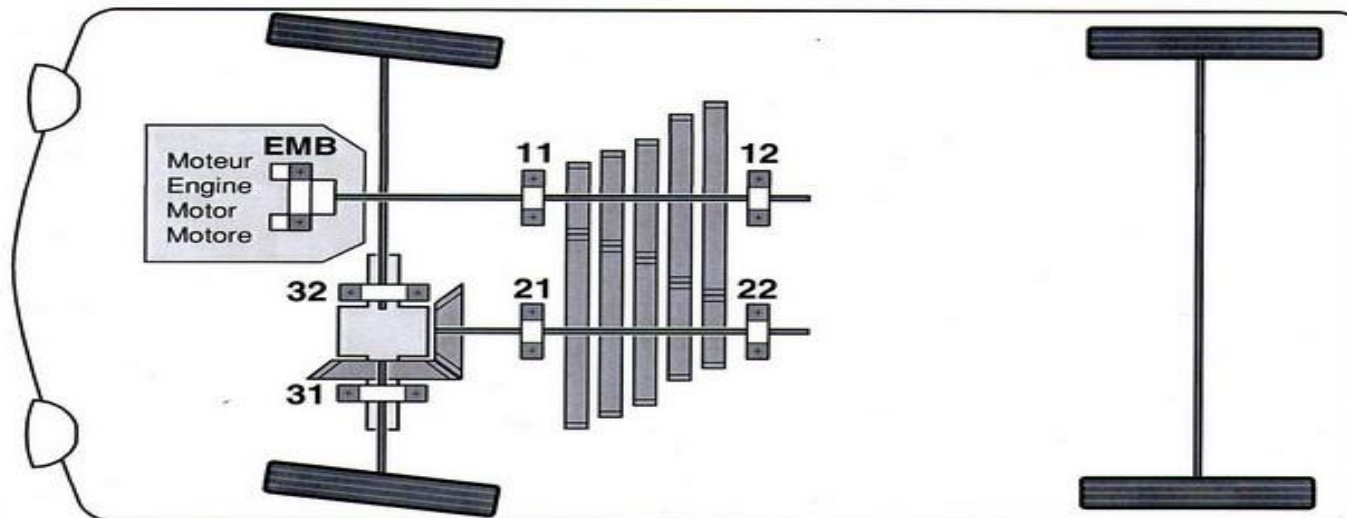

OE



<b>11</b>	7703090021	NU 2203 WNF210	17	40	16	H05
<b>12</b>	7703090032	X10D 30205 A	25	52/58	28,75	L64
<b>21</b>	-					
<b>22</b>	7703090181	FC 10558 V	25	67/75	40,5	L64
<b>31</b>	7703090187	30207 A	35	72	18,25	K01
<b>32</b>	7703090179	10Q 30207 A	37	72	18,25	K01

RENAULT

R17 ..... P.48

Ce que l'on retrouve comme roulements sur le catalogue SNR des BV 365.

A noter NU 2203 WNF 210 a disparu de la circulation.

A noter X10D30205A a également disparu de la circulation.....entre 2007 et 2011.....



**Doc SNR 2011.**  
**OE**



365					
<b>10Q 30207 A</b>					
	7703090179	37	72	18,25	
<b>30207 A</b>					
	7703090187	35	72	18,25	
<b>BR10552</b>					
	7700522451	32	70	20	
<b>FC 10558 V</b>					
	7703090181	25	67/75	40,5	

Sur ce document les côtes du BR10552 sont fausses; et pas d'indication de schéma(H5).

BV 365 R17 R12G A310 4 cylindres.....et Berlinettes 1600 SC (type 1600 VD).



# Doc SNR 2007.

385

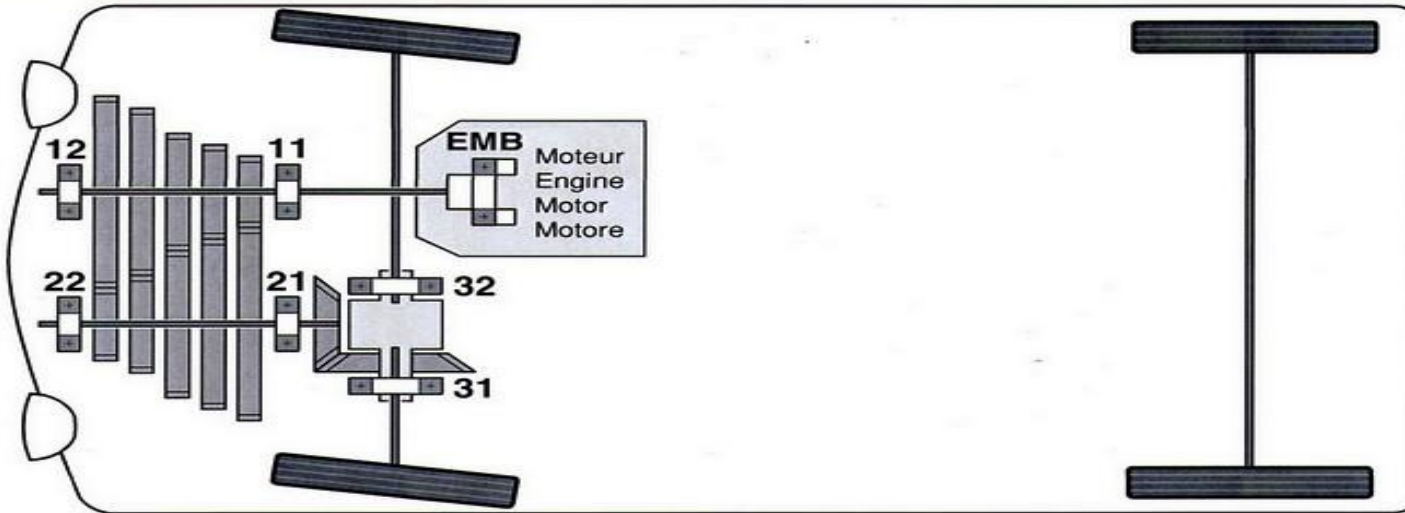

OE



<b>EMB</b> 840.25	7701348231	<b>BAC 340 NY 06 B</b>				
<b>11</b>	7703090021	<b>NU 2203 WNF210</b>	17	40	16	H05
<b>12</b>	7703090032	<b>X10D 30205 A</b>	25	52/58	28,75	L64
<b>21</b>	7703090201	<b>N 10787</b>	32	72	19	H02
<b>22</b>	7703090181	<b>FC 10558 V</b>	25	67/75	40,5	L64
<b>31</b>	7703090187	<b>30207 A</b>	35	72	18,25	K01
<b>32</b>	7703090179	<b>10Q 30207 A</b>	37	72	18,25	K01

## RENAULT

R5 ..... P.46  
 R16 ..... P.48

Pas mention de GB10890 S01 2ème montage de roulement d'arbre primaire côté carter de 5ème des BV 385.